

Referencia / Item

2175

Caja empotrable para empalmes con tapa de cierre por tornillos.
 Enlazable horizontalmente. *Junction box with cover, closed by screws.*
Horizontally linkable.

Características / Features	
Instalación / <i>Installation:</i>	Empotrar / <i>Flush-mounting</i>
Entradas / <i>Intake:</i>	19
Uso / <i>Use:</i>	Interior / <i>Indoor</i>
Dimensiones envolvente / <i>Box dimensions:</i>	(319,6 x 144,2 x 59) mm.
Dimensiones hueco empotrar / <i>Hole wall dimensions:</i>	(320 x 145 x 60) mm.
Color / <i>Colour:</i>	Grey RAL 7035 / <i>Grey RAL 7035</i>
Peso / <i>Weight:</i>	422 g.
Componentes / <i>Components:</i>	Con 6 tornillos referencia 2000-20 incluidos. Juego de 2 Tabiques separadores referencia 25757 (no incluidos) / <i>6 screws item 2000-20 are included. 1 kit separation partitions, item 25757, are not included.</i>
Material plástico / <i>Plastic material:</i>	ABS

Datos técnicos / Technical data	
Tensión máxima / <i>Maximum voltage:</i>	400 V.
Resistencia al hilo incandescente / <i>Incandescent wire resistance:</i>	650 °C
Uso / <i>use:</i>	Interior / <i>Indoor</i>
Grade de protección IP / <i>IP Protection degree:</i>	IP 30
Ensayo de bola a presión / <i>Ball press test:</i>	70 °C
Material libre de halógenos / <i>Halogen free:</i>	Sí / <i>Yes</i>

Normativa / Standards	
Norma de producto / <i>According to:</i>	UNE-EN IEC 60670-1 y UNE-EN IEC 60670-22 / <i>UNE-EN IEC 60670-1 and UNE-EN IEC 60670-22</i>
Declaración de conformidad (CE) / <i>Declaration of Conformity (CE):</i>	Sí / <i>Yes</i>

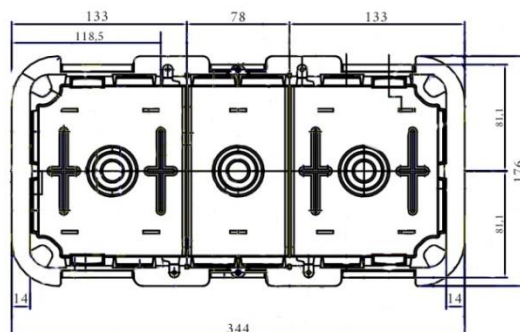
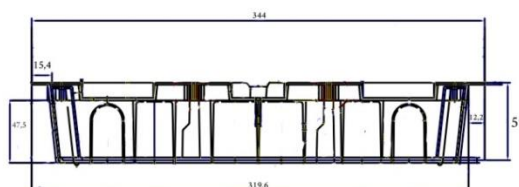

Embalaje y logística

Embalaje / <i>Packaging</i>	Cantidad / <i>Quantity</i>	Peso (g.) / <i>Weight (g.)</i>	Dimensiones / <i>Dimensions</i>	Código de barras / <i>Barcode</i>
N/A	1 ud.	422 g.	(362 x 193 x 61) mm	8428088026255

Retractiladas a 5 unidades y embaladas a 60 unidades. *Plastic film: 5 pcs. and box: 60 pcs.*